



TRENCH HEATERS FCHV

 FOR HEATING

 FOR COOLING

 VENTILATION

 FAN ASSISTED

- 10 models
- Stainless steel casings
- 2 and 4 pipes versions
- Wet cooling and dry cooling ready
- Remarkably low noise level
- Tested according to EN16430 in independent accredited laboratory
- 10 year warranty for casings and heat exchangers
- Fans with most economical and quiet EC type motors
- High rise of cooled air
- Excellent compatibility with heat pumps and condensate boilers
- Max operating pressure 25 bar
- Possibility to control up to 30 units with 1 room thermostat
- Highly efficient and economic copper-aluminium heat exchangers
- Safe voltage of fans – 24V (DC)
- Supply air filters are in standard set
- Reversible reinforced profile grilles
- All fixing brackets and bolts have sound proofing elements
- Possibility to change level of casing at any time during exploitation (when installed in raised floors)



2023



FCHV

TRENCH HEATERS FCHV

FCHV are among the most powerful trench heaters designed for **heating and cooling**. In addition, it has an option to **supply air from a ventilation system into the room**. Ventilation ducts are connected directly to the casing from the side of the room. In this way, **fresh air** bypasses the heating-cooling unit and **a wide stream of air is supplied via the window**.

Both heated and cooled air is raised right up the ceiling to result in an **even distribution** throughout the room.

4 and 2 pipe connection versions are available. The 4 pipe connection guarantees maximum flexibility, whereas the 2 pipe connection will ensure the maximum capacity.

The air flow passing through the appliance is **continuously filtered** to trap a considerable part of the dust and dirt in the room and protect the convector from contamination.

Include **drain pans** that allow the device to operate both above and below the dew point.

Quiet and extremely economical EC fans increase the convection efficiency more than 4 times, almost without any sound.

Due to **extremely low inertia**, can quickly increase and precisely maintain the set room temperature, **providing the room with exactly as much heat as you require just when it is required**.

Create an effective warm air curtain for large windows, without allowing cold to penetrate the premises. The **heat is perfectly distributed** throughout the room.

Operates very well with **low-temperature heat sources**, such as heat pumps or condensing boilers.

Fully floor-mounted, and therefore **do not impede free passage**.

Perfect for any interior, as the only visible element is the grill, the material and colour of which can match the floor covering.

May be walked on and can easily **withstand the weight of a number of adults**.

Supplied with a **stainless steel casings** and **copper-aluminium heat exchangers**, to ensure they remain extremely reliable over the long-term.



10-year warranty for the casings and heat exchangers

We are confident in the longevity of our housings and heat exchangers; therefore, we provide them with a 10-year guarantee.



Tested according to EN16430

The outputs of all products manufactured by Konveka have been tested by independent accredited laboratories according to the latest standards.

With us, 1 kW means 1 kW.



Fans with EC technology

All Konveka forced convection devices are equipped with fans that employ **EC technology**. This is far superior to AC technology, as the fans:

1. Are **7 times more economical**.
2. Brushless motors are more durable and are **maintenance-free**.
3. Speed is **adjustable stepless**, using only as much power as required.
4. Starting currents do not exceed the operating currents.
5. Minimum rotation speed is 10% (out of max.)



Work perfectly with low-temperature energy carriers

Due to their high efficiency, FCHV are very **suitable for** operating with low-temperature energy carriers, such as **heat pumps** and **condensing boilers**.



Sound insulation

All the supporting parts have sound-insulating elements, to prevent the spread of sound to the premises below.



Especially quiet operation

We have achieved exceptionally low noise levels using **extremely quiet EC fans** and by the **optimisation** of their **rotational speed** and **design** of the devices.



All body parts are made of stainless steel Stainless steel provides **100% corrosion protection** for an indefinite time. It is also **54% stronger** and **45% harder** than carbon steel, so it can withstand loads during transportation, installation, and operation.



Reinforced casings

As a standard, the FCHV convector casings are equipped with:

1. **Stiffening elements** to maintain the pressure of the concrete – from 2 to 3 pcs, depending on the length of the casing.
2. M10 **support screws** to withstand the vertical load – from 4 to 12 pcs.
3. Mounting **brackets** for attaching the casing to the floor – 4 pcs.

These structural elements, together with the strong casing material, ensure their stable shape during installation, transportation and operation.



Maximum operating pressure – 25 bar

All the devices are **factory-tested** for leaks at a pressure of **30 bar**. The maximum maintained pressure (strength limit) is **110 bar**. Konveka devices easily withstand hydraulic tests, hydraulic shocks and can be installed in extremely tall buildings.



Safe operating voltage of fans

The operating voltage of all fans is 24V DC. This voltage is safe for humans.

STANDARD SET

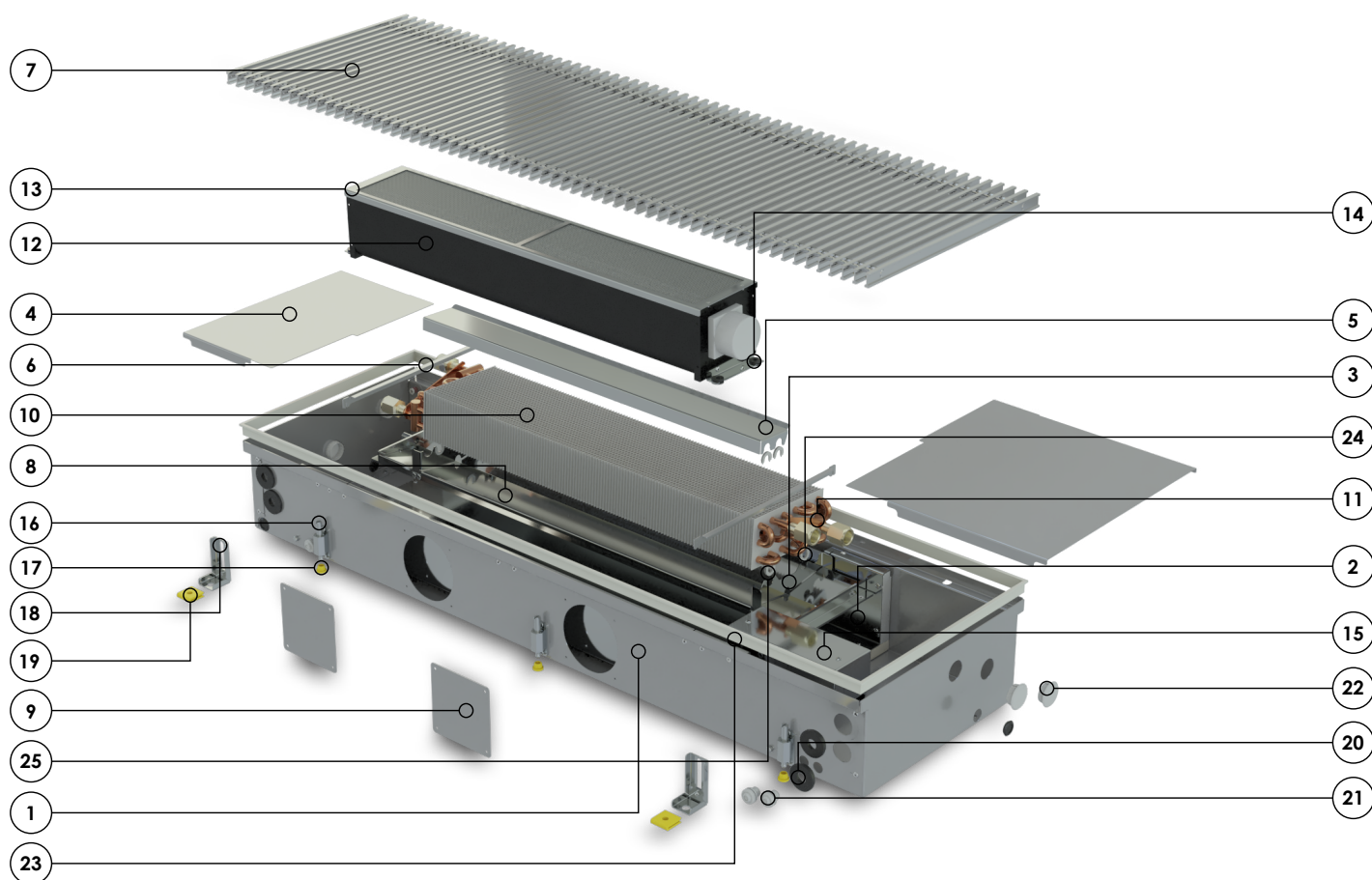

FCHV

- ① Stainless steel casing
- ② Inner stainless steel casing
- ③ Brackets for heat exchanger
- ④ Hydraulic connections cover
- ⑤ Air guiding element
- ⑥ Casing's stiffening elements
- ⑦ Protective - decorative grille (optional)
- ⑧ Drain pan
- ⑨ Covers for holes for air ducts
- ⑩ Copper - aluminium heat exchanger
- ⑪ Air vent
- ⑫ Fan with EC motor
- ⑬ Air filter
- ⑭ Vibration dampers for fan
- ⑮ Control box (optional)
- ⑯ Height adjustment and vertical load supporting bolts
- ⑰ Noise isolating elements for adjusting screws
- ⑱ Casing fixing to the floor brackets
- ⑲ Noise isolation elements for floor brackets
- ⑳ Pipe sealing and protection elements
- ㉑ Cable sealing and protection elements
- ㉒ Plugs for unused casing holes
- ㉓ Anodized aluminium frame; colour matches the colour of grille
- ㉔ Heat exchanger fixing - protecting elements

All fasteners required for installation
Installation manual

5-layer, 2 parts cardboard box, additionally used for device protecting during installation and construction works

OVERVIEW

FCHV2 (2-pipe version).....	6
5 models	
Lengths	120, 170, 200, 250, 300 cm
Width	36 cm
Height	15 cm
FCHV4 (4-pipe version).....	9
5 models	
Lengths	120, 170, 200, 250, 300 cm
Width	36 cm
Height	15 cm
ACCESORIES.....	12
ELECTRICAL CONNECTION DIAGRAMS.....	13
GRILLES.....	14
ABOUT KONVEKA	16

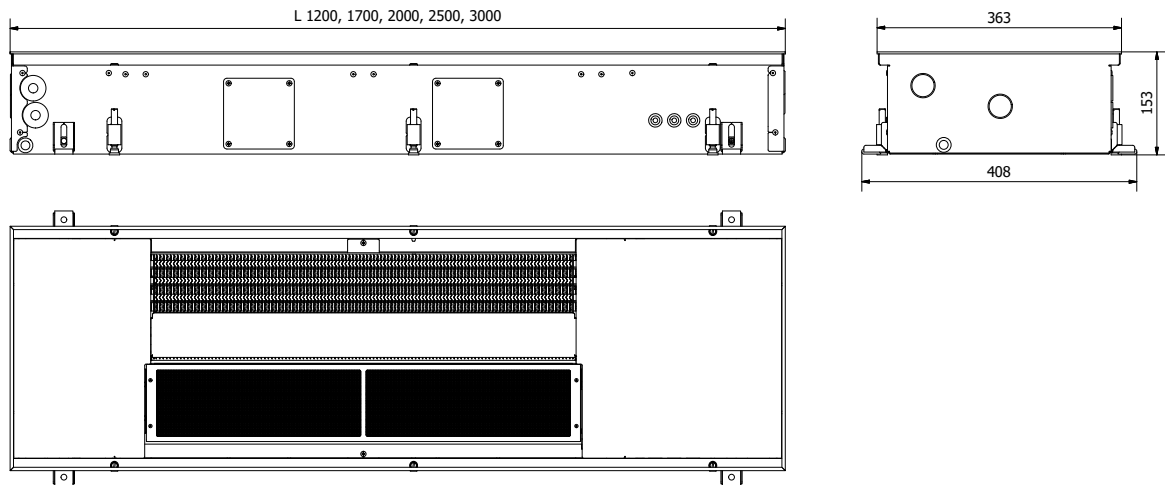

TECHNICAL DATA

Length	1200-3000 mm	Thread of hydr. connections	G 1/2"
Width	363 mm	Thread type of hydr. connections	inner
Height = installation height	153 mm	Position of the hydr. connections	1 side
Type of fan motors	EC	Operating pressure	25 bar
Fan operating voltage	24V DC	Operating temperature	2 - 120°C
Fan speed control voltage	0 - 10V		

EN16430 certified outputs

Fan speed	Heat outputs, W			Sensible cooling outputs, W			Sound levels		Air flow m ³ /h	Inlet fresh air flow rate, m ³ /h
	75/65/20°C Δt = 50°C	55/45/20°C Δt = 30°C	35/30/20°C Δt = 12,5°C	7/12/27°C Δt = 17,5°C	7/12/25°C Δt = 15,5°C	14/17/25°C Δt = 9,5°C	Sound pressure level, dB(A)	Sound power level, dB(A)		
FCHV2 120										
100%	3 418	2 072	879	1 014	905	574	41	49	0 - 383	160
80%	3 052	1 851	785	837	748	474	36	45		
60%	2 523	1 530	649	654	584	371	28	37		
40%	1 830	1 110	471	462	413	262	23	32		
20%	973	590	250	255	228	145	20	29		
FCHV2 170										
100%	6 152	3 730	1 582	1 824	1 630	1 033	42	51	0 - 520	160
80%	5 494	3 332	1 413	1 507	1 346	854	41	50		
60%	4 542	2 754	1 168	1 178	1 052	667	34	44		
40%	3 294	1 997	847	832	743	471	29	38		
20%	1 751	1 061	450	459	410	260	25	35		
FCHV2 200										
100%	6 835	4 144	1 758	2 027	1 811	1 148	44	53	0 - 766	240
80%	6 105	3 702	1 570	1 674	1 495	948	39	48		
60%	5 047	3 060	1 298	1 308	1 169	741	31	41		
40%	3 660	2 219	941	924	826	524	24	34		
20%	1 945	1 179	500	510	456	289	22	32		

Fan speed	Heat outputs, W			Sensible cooling outputs, W			Sound levels		Air flow m ³ /h	Inlet fresh air flow rate, m ³ /h
	75/65/20°C Δt = 50°C	55/45/20°C Δt = 30°C	35/30/20°C Δt = 12,5°C	7/12/27°C Δt = 17,5°C	7/12/25°C Δt = 15,5°C	14/17/25°C Δt = 9,5°C	Sound pressure level, dB(A)	Sound power level, dB(A)		
FCHV2 250										
100%	9 569	5 802	2 462	2 838	2 535	1 608	43	54	0 - 903	240
80%	8 547	5 182	2 199	2 344	2 094	1 328	40	50		
60%	7 065	4 284	1 817	1 832	1 636	1 038	33	43		
40%	5 124	3 107	1 318	1 294	1 156	733	26	37		
20%	2 723	1 651	700	714	638	405	24	33		
FCHV2 300										
100%	12 303	7 460	3 165	3 649	3 259	2 067	43	54	0 - 1 040	320
80%	10 989	6 663	2 827	3 014	2 692	1 707	42	53		
60%	9 084	5 508	2 337	2 355	2 104	1 334	33	44		
40%	6 588	3 995	1 695	1 664	1 486	942	27	38		
20%	3 501	2 123	901	918	820	520	24	35		

Heat outputs at specific temperatures are available at www.konveka.lt

Model	Length, mm	No. of fans, pc	Max el. power, A	Max el. power, W	Length of heat exchanger, mm	Weight, kg	Water volume, l
FCHV2 120	1 200	1	0,63	15	675	21,2	0,77
FCHV2 170	1 700	1	0,75	18	1 189	28,9	1,35
FCHV2 200	2 000	2	1,25	30	1 431	33,9	1,62
FCHV2 250	2 500	2	1,38	33	1 945	42,2	2,21
FCHV2 300	3 000	2	1,50	36	2 458	51,5	2,79

FCHV2

Pressure losses

Length, cm	MAX flow	MAX power	Formulas for pressure losses, Pa
120	294	3 418	$0,60 \times (0,084965151641 \times q^2 - 2,734953599329 \times q + 220,629894249638)$
170	529	6 152	$1,08 \times (0,084965151641 \times q^2 - 2,734953599329 \times q + 220,629894249638)$
200	588	6 835	$1,20 \times (0,084965151641 \times q^2 - 2,734953599329 \times q + 220,629894249638)$
250	823	9 569	$1,68 \times (0,084965151641 \times q^2 - 2,734953599329 \times q + 220,629894249638)$
300	1058	12 303	$2,16 \times (0,084965151641 \times q^2 - 2,734953599329 \times q + 220,629894249638)$

q – Flow of energy carrier (l/h)

EXAMPLE OF CONNECTIONS

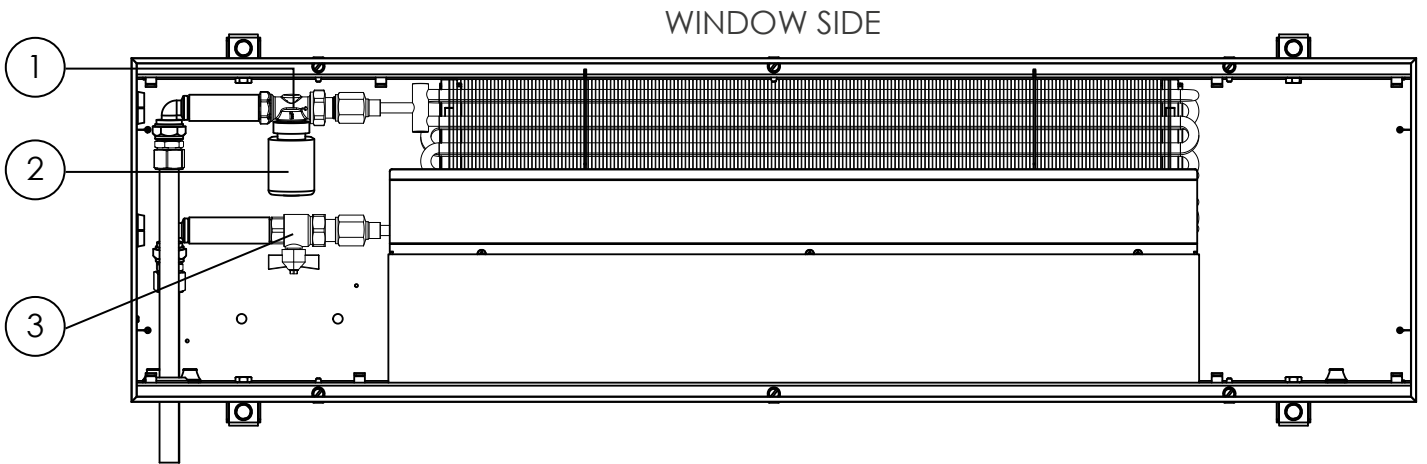

- ① Thermostatic valve, straight ② Thermostatic valve actuator ③ Straight lockshield valve

INSTALLATION FEATURES

- Side with heat exchanger is always mounted closer to the window (wall)
- Energy carrier supply pipes has to be connected to heat exchangers connectors which are further from the fans
- Energy carrier outlet pipes has to be connected to heat exchangers connectors which are closer to the fans
- Height of the device can be adjusted at any time of exploitation (when installed in raised floor)

ORDER CODES

Type	Length, cm	Width, cm	Height, cm	Example
FCHV2	250	36	15	FCHV2 250

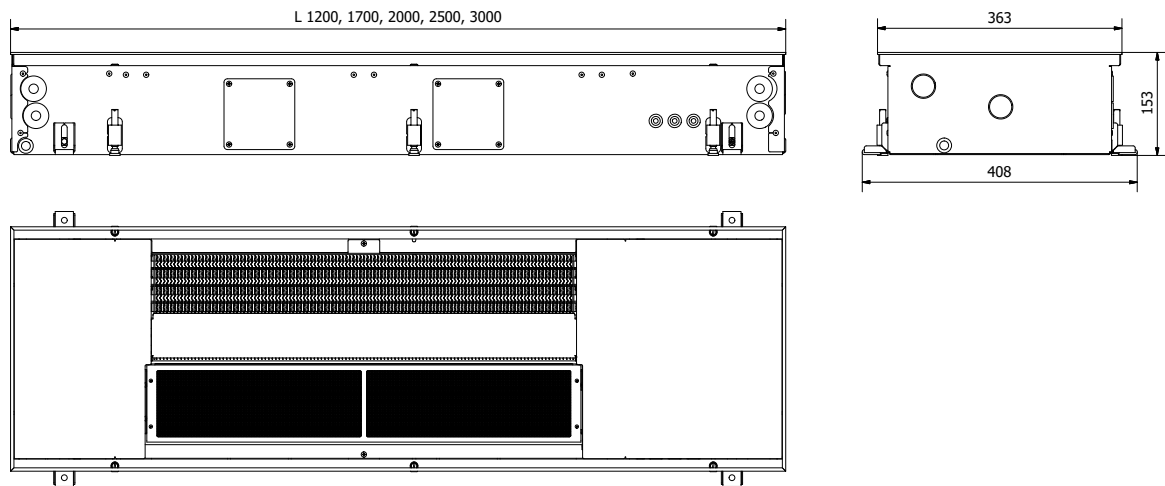

TECHNICAL DATA

Length	1200-3000 mm	Thread of hydr. connections	G 1/2"
Width	363 mm	Thread type of hydr. connections	inner
Height = installation height	153 mm	Position of the hydr. connections	1 side
Type of fan motors	EC	Operating pressure	25 bar
Fan operating voltage	24V DC	Operating temperature	2 - 120°C
Fan speed control voltage	0 - 10V		

EN16430 certified outputs

Fan speed	Heat outputs, W			Sensible cooling outputs, W			Sound levels		Air flow m ³ /h	Inlet fresh air flow rate, m ³ /h
	75/65/20°C Δt = 50°C	55/45/20°C Δt = 30°C	35/30/20°C Δt = 12,5°C	7/12/27°C Δt = 17,5°C	7/12/25°C Δt = 15,5°C	14/17/25°C Δt = 9,5°C	Sound pressure level, dB(A)	Sound power level, dB(A)		
FCHV4 120										
100%	2 013	1 196	490	960	857	544	41	49	0 - 383	160
80%	1 859	1 104	452	808	722	458	36	45		
60%	1 661	986	404	647	578	367	28	37		
40%	1 380	820	336	473	423	268	23	32		
20%	901	535	219	277	247	157	20	29		
FCHV4 170										
100%	3 624	2 152	881	1 728	1 542	979	42	51	0 - 520	160
80%	3 347	1 988	814	1 454	1 299	824	41	50		
60%	2 989	1 775	727	1 165	1 040	660	34	44		
40%	2 485	1 476	604	852	761	482	29	38		
20%	1 623	964	395	499	445	283	25	35		
FCHV4 200										
100%	4 026	2 392	980	1 920	1 714	1 088	44	53	0 - 766	240
80%	3 718	2 208	904	1 616	1 444	916	39	48		
60%	3 322	1 972	808	1 294	1 156	734	31	41		
40%	2 760	1 640	672	946	846	536	24	34		
20%	1 802	1 070	438	554	494	314	22	32		

Fan speed	Heat outputs, W			Sensible cooling outputs, W			Sound levels		Air flow m ³ /h	Inlet fresh air flow rate, m ³ /h
	75/65/20°C Δt = 50°C	55/45/20°C Δt = 30°C	35/30/20°C Δt = 12,5°C	7/12/27°C Δt = 17,5°C	7/12/25°C Δt = 15,5°C	14/17/25°C Δt = 9,5°C	Sound pressure level, dB(A)	Sound power level, dB(A)		
FCHV4 250										
100%	5 637	3 348	1 371	2 688	2 399	1 523	43	54	0 - 903	240
80%	5 206	3 092	1 266	2 262	2 021	1 282	40	50		
60%	4 650	2 761	1 131	1 812	1 618	1 027	33	43		
40%	3 865	2 296	940	1 325	1 184	750	26	37		
20%	2 524	1 499	614	776	692	440	24	33		
FCHV4 300										
100%	7 248	4 304	1 762	3 456	3 084	1 958	43	54	0 - 1 040	320
80%	6 694	3 976	1 628	2 908	2 598	1 648	42	53		
60%	5 978	3 550	1 454	2 330	2 080	1 320	33	44		
40%	4 970	2 952	1 208	1 704	1 522	964	27	38		
20%	3 246	1 928	790	998	890	566	24	35		

Heat outputs at specific temperatures are available at www.konveka.it

Model	Length, mm	No. of fans, pc	Max el. power, A	Max el. power, W	Length of heat exchanger, mm	Weight, kg	Water volume, l	
							Heating	Cooling
FCHV4 120	1 200	1	0,63	15	675	21,2	0,17	0,60
FCHV4 170	1 700	1	0,75	18	1 189	28,9	0,30	1,05
FCHV4 200	2 000	2	1,25	30	1 431	33,9	0,36	1,26
FCHV4 250	2 500	2	1,38	33	1 945	42,2	0,49	1,72
FCHV4 300	3 000	2	1,50	36	2 458	51,5	0,62	2,17

Pressure losses (heating)

Length, cm	MAX flow	MAX power	Formulas for pressure losses, Pa
120	173	2 013	$(L - 0,60) \times (0,077284346706 \times q^2 + 10,657268943232 \times q - 756,077513728194)$
170	312	3 624	$(L - 0,62) \times (0,077284346706 \times q^2 + 10,657268943232 \times q - 756,077513728194)$
200	346	4 027	$(L - 0,80) \times (0,077284346706 \times q^2 + 10,657268943232 \times q - 756,077513728194)$
250	485	5 638	$(L - 0,82) \times (0,077284346706 \times q^2 + 10,657268943232 \times q - 756,077513728194)$
300	623	7 249	$(L - 0,84) \times (0,077284346706 \times q^2 + 10,657268943232 \times q - 756,077513728194)$

Pressure losses (cooling)

Length, cm	MAX flow	MAX power	Formulas for pressure losses, Pa
120	147	857	$(L - 0,60) \times (0,03410567137 \times q^2 + 6,253189479095 \times q - 425,969877062125)$
170	265	1 543	$(L - 0,62) \times (0,03410567137 \times q^2 + 6,253189479095 \times q - 425,969877062125)$
200	295	1 715	$(L - 0,80) \times (0,03410567137 \times q^2 + 6,253189479095 \times q - 425,969877062125)$
250	413	2 401	$(L - 0,82) \times (-0,009104212051 \times q^2 + 11,06155128551 \times q - 916,512265061525)$
300	531	3 087	$(L - 0,84) \times (-0,009104212051 \times q^2 + 11,06155128551 \times q - 916,512265061525)$

L – Length of trench heater (m) q – Flow of energy carrier (l/h)

EXAMPLE OF CONNECTIONS

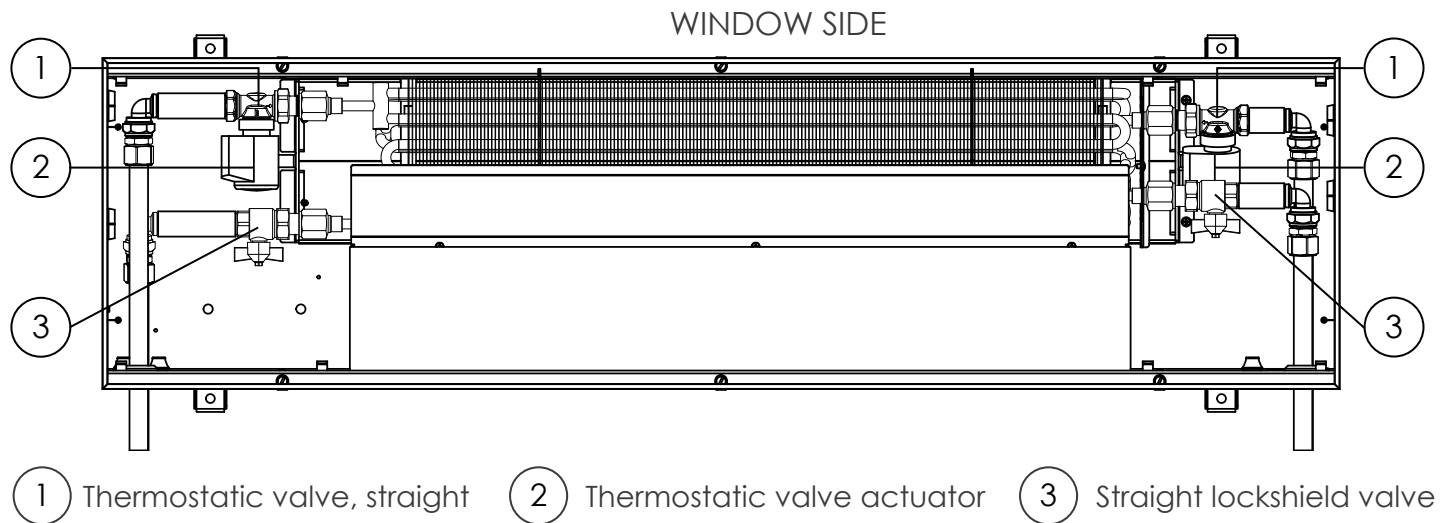

INSTALLATION FEATURES

- The side with the heat exchanger is always mounted closer to the window (wall)
- Possibility to connect pipes through the side or end of the convector
- The 4-pipe heat exchanger has two independent circuits. They are connected to the heating and cooling systems on both sides of the device as follows:
 - To a heating system – on a side of the control box;
 - To a cooling system – on a side of condensate water outlet.
- Energy carrier supply have to be connected to heat exchanger connection which is further from fans
- Outgoing pipes of both circuits have to be connected to the heat exchanger's connections which is closer to fans
- All fasteners required for mounting are included in the standard kit
- The possibility of adjusting the height of the device after mounting (when mounting into raised floor)

ORDER CODES

Type	Length, cm	Width, cm	Height, cm	Example
FCHV4	250	36	15	FCHV4 250

ACCESSORIES

THERMOSTATIC VALVE **TVS15**

Controls flow of energy carrier. Controlled by thermal actuator A24NC



Controls flow with thermoelectric actuator

Provides possibility to close flow and disconnect heat exchanger from heating system without draining

DN15 Kvs = 2,00

LOCKSHIELD VALVE (STRAIGHT) **LS15**

Opens, closes or limits flow of energy carrier



For energy carrier opening, closing and presetting of maximal flow

Provides possibility to close flow and disconnect heat exchanger from heating system without draining

DN15 Kvs = 1,74

DN20 Kvs = 1,93

LOCKSHIELD VALVE (ANGLE) **LA15**

Opens, closes or limits flow of energy carrier



For energy carrier opening, closing and presetting of maximal flow

Provides possibility to close flow and disconnect heat exchanger from heating system without draining

DN15 Kvs = 1,74

DN20 Kvs = 1,93

THERMOSTATIC VALVE ACTUATOR **A24NC**

Opens / closes thermostatic valve. Controlled by room thermostat TW24



Opening/closing of thermostatic valves (ON/OFF)

Thermoelectric

Opened/Closed indicator

Voltage 24V DC

ROOM THERMOSTAT **TW24**

Controls thermal actuator A24NC and fans according to preset room temperature



For maintaining the set room temperature

Day/night and weekly temperature programmes

Accuracy of temperature control $\pm 0,5^{\circ}\text{C}$

Power supply of 24V DC

Stepless fan rotating speed control, 0-10 V

Valve actuator control (ON/OFF)

Backlit LED display

ELECTRIC CONTROL BOX **CB60**

For power supply of fans, actuators A24NC and room thermostat TW24

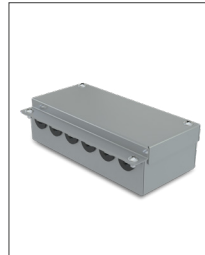

Can be installed inside convector's casing

Ensures easy and fast connection between convector and room thermostat

24V DC power supply included

El. connectors for fast connection of the cables included

ORDER CODES

Accessory	Order code
Thermostatic valve	TVS15
Thermostatic valve actuator	A24NC
Lockshield valve (angle)	LA15
Lockshield valve (straight)	LS15
Room thermostat	TW24
Electric control box	CB60

CONNECTION DIAGRAMS

CONNECTION OF ONE FCHV TO ROOM THERMOSTAT

CONNECTION OF FEW FCHV TO ROOM THERMOSTAT

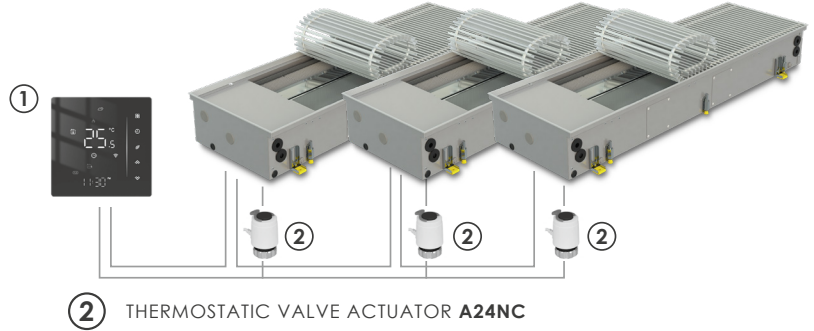
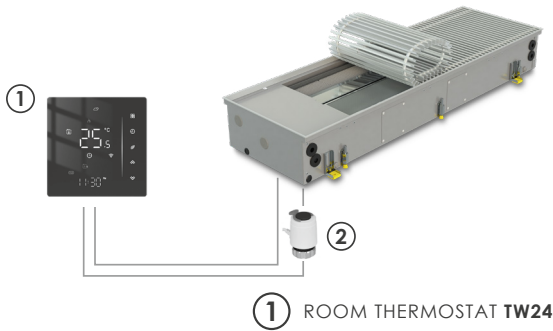

WIRING DIAGRAM FCHV2

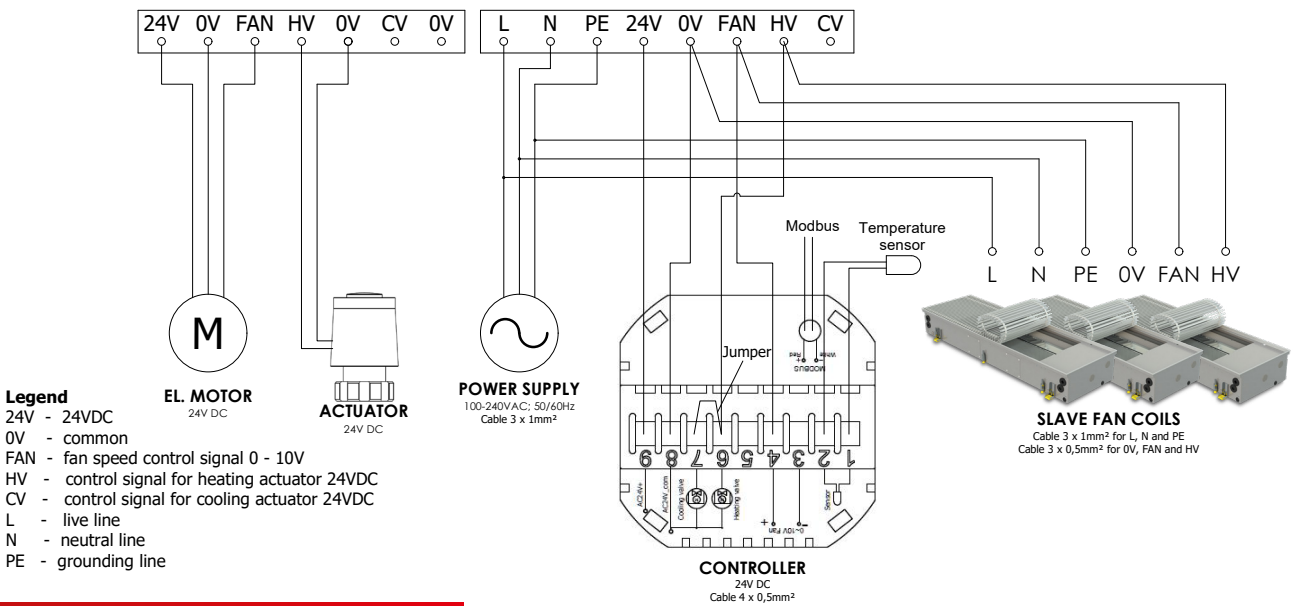

WIRING DIAGRAM FCHV4

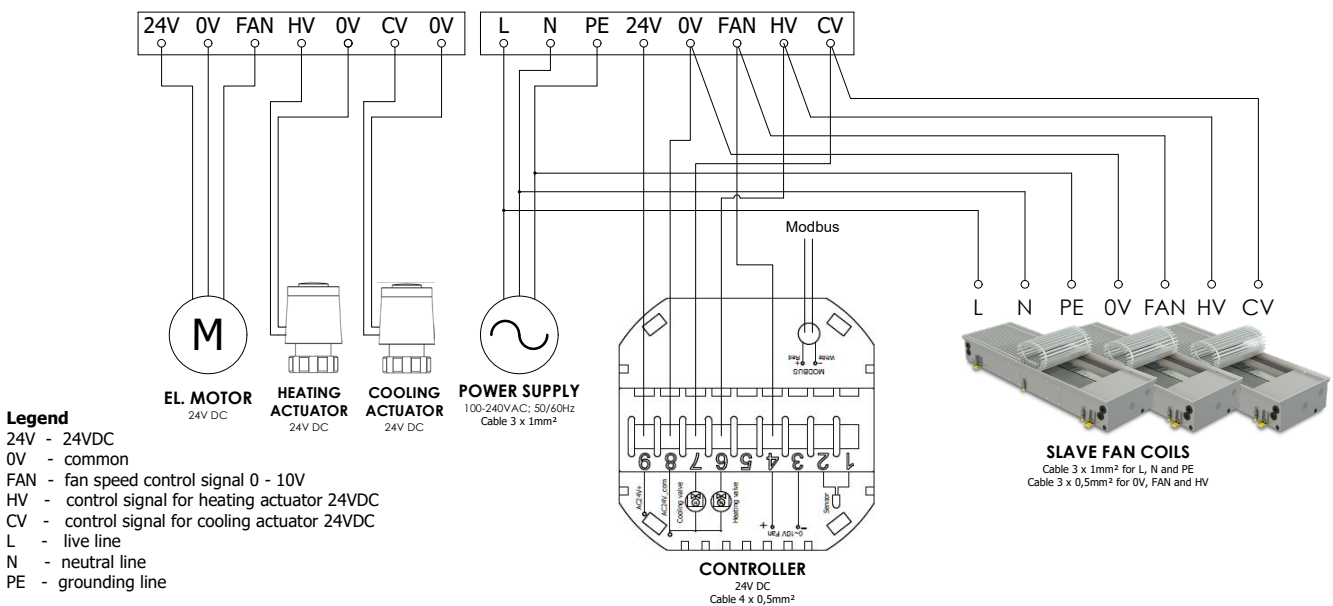

- Trench heaters installed in the same room are controlled based on the Master - Slave principle
- Speed of fans are controlled 0-10 V by room thermostat. Voltage – 24VDC
- Valve actuators are controlled ON/OFF by room thermostat. Voltage – 24VDC
- Up to 30 trench heaters can be controlled with one room thermostat TW24

GRILLES

ALUMINIUM ROLL-UP GRILLES

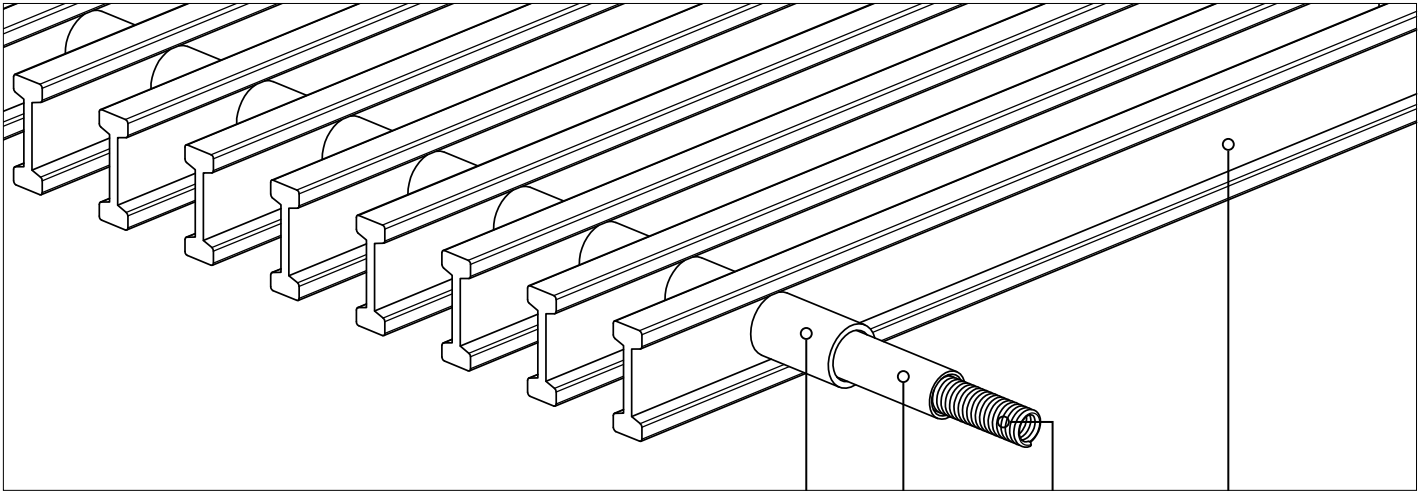

GRILLE PROFILE

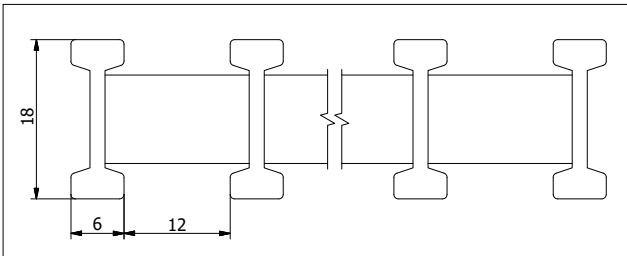

2 4 3 1

1 Aluminium profile

- made of anodized aluminium
- reinforced reversable double T profile

2 Spacers

- made of anodized aluminium
- does not shrink or crack when exposed on UV or heat
- the colour is exactly the same as colour of profiles

3 Spring

4 Flexible protective pipe

SILVER (ALS)

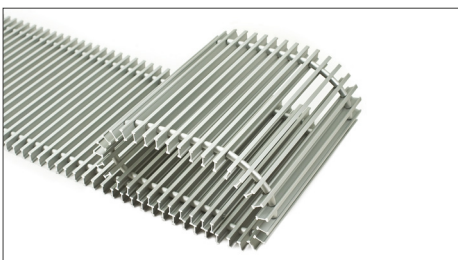

BROWN (AL 10)

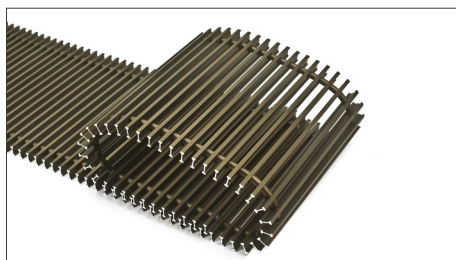

BLACK (AL 50)

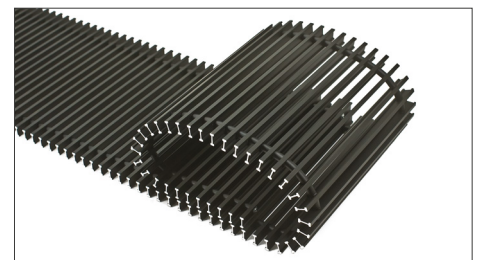

ALUMINIUM LINEAR GRILLES

SILVER (ALS)



BROWN (AL 10)

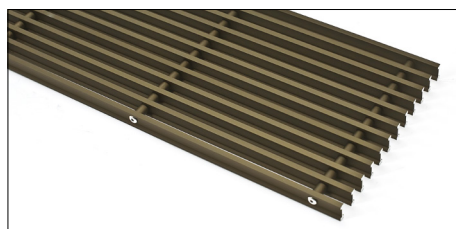

BLACK (AL 50)



WOODEN ROLL-UP GRILLES

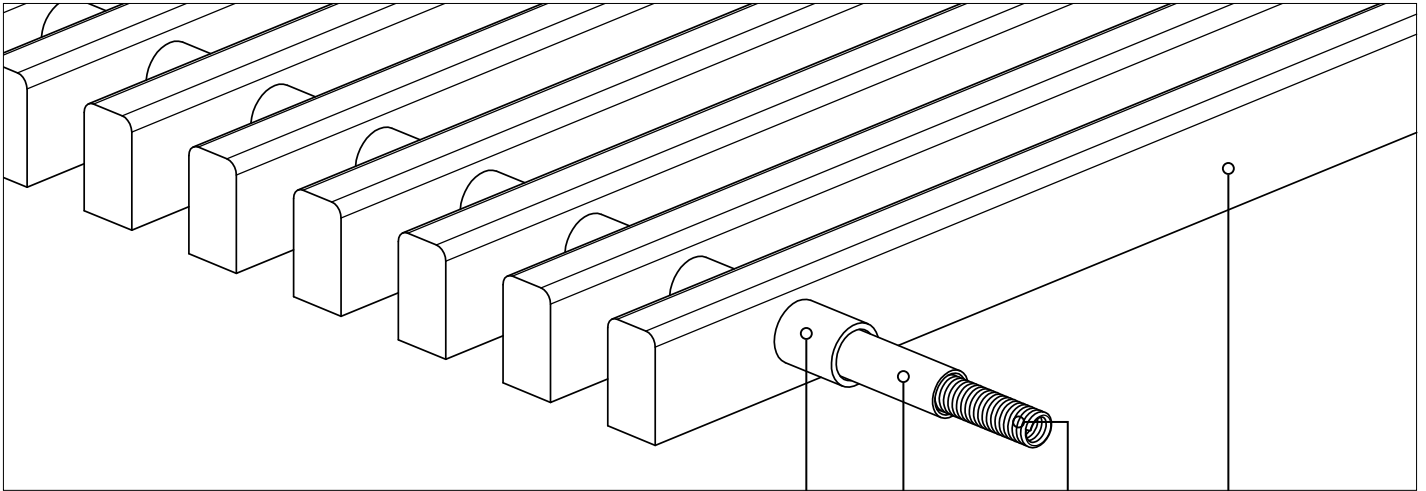

GRILLE PROFILE

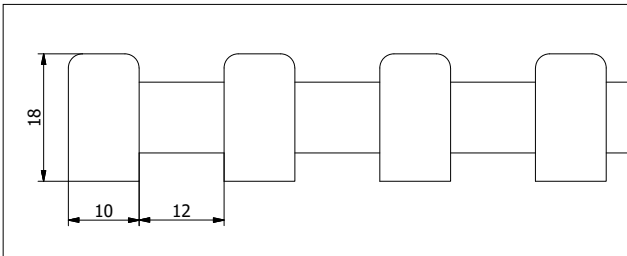

- ②
- ④
- ③
- ①

① **Wooden profile**
- made of solid wood

② **Spacers**
- made of anodized aluminium
- does not shrink or crack when exposed on UV or heat

③ **Spring**

④ **Flexible protective pipe**

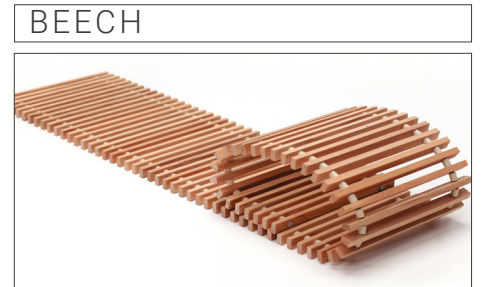
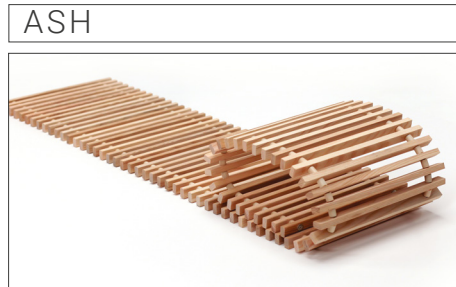

ORDER CODE FOR GRILLES

Type	Length, cm	Width, cm	Material	Example
GR	200	36	ALS	GR 200-36 ALS

ABOUT KONVEKA

Konveka is a **full production cycle convector manufacturing company** engaged in this activity **since 2005**. The range of products we develop and manufacture is wide: from simple natural convection convectors to complex devices with fans for heating, cooling and ventilation.

Konveka is a manufacturer of high-quality and reliable convectors:

- We provide a **5 - 10 year warranty for all our products** (except their electrical part) without any additional warranty extension fees.
- **The capacities of all our products are determined by independent accredited laboratories** according to current standards. With us, 1kW means 1kW.
- We **do not use cheap, unapproved solutions or use unreliable materials** when designing and manufacturing our devices.

Although we operate in a highly competitive international market, **we are at the forefront where quality, durability and reliability are valued.**

We are well known in **Eastern and Western Europe, Scandinavia, North America and Central Asia**. Konveka products can be seen in many prestigious buildings around the world: administrative buildings, shopping malls, airports, restaurants, theaters, universities, hotels, apartment buildings and individual homes. Visit our website www.konveka.com for more information.

Konveka consistently wins **national awards** (see below) for **reliability, consistency and business growth**.

Our slogan - **“More than you expected”** reflects the quality of our products and technical solutions, which often exceed customer expectations. We value our customers and are happy to be a part of their successful business.

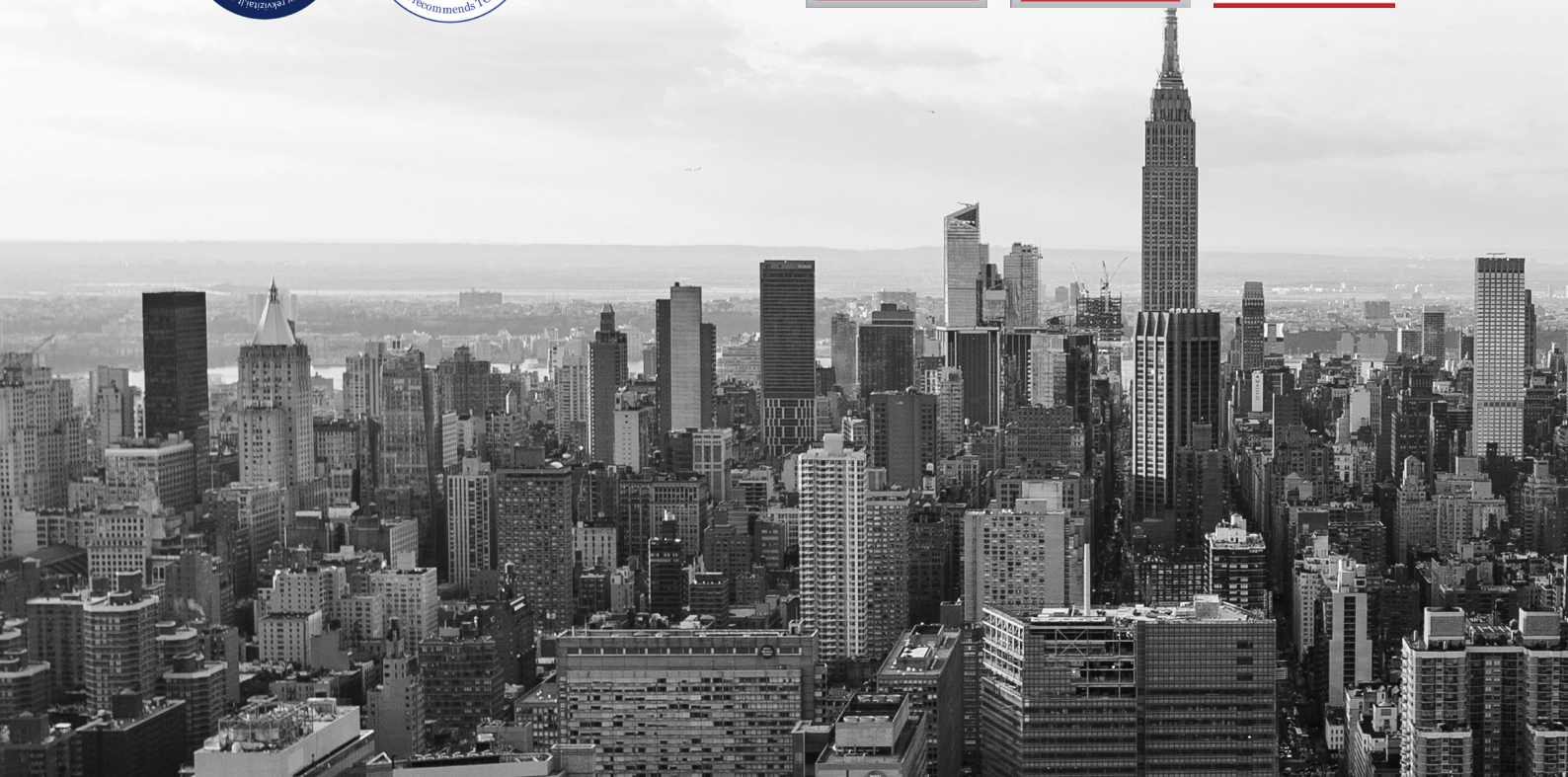



Konveka, UAB
Vokieciu 185, LT-45251 Kaunas
Tel. +370 600 05968, +370 677 06303
Email: donatas@konveka.lt, sales@konveka.lt

www.konveka.com